

HOW DOES UV “KILL” AIRBORNE PATHOGENS?

UV-C reacts with cell DNA, causing alterations which result in organism self-destruction. UV-C destroys organisms anywhere the Ultraviolet light can penetrate and it is particularly effective against viruses, which range in size from 0.003 to 0.06 microns. The destruction of micro-organisms is accomplished when the UV-C rays directly strike them. The kill ratio of course is dependent on time and exposure and the intensity of the UV-C rays. Thus micro-organisms that come in direct contact can be readily destroyed. However, if the micro-organism whether it be bacteria or mold spores, is hidden below the surface, or if the microbe is not in the direct path of the rays, they will not be destroyed. As the UV-C rays strike the organism, the organism starts to swell which weakens the cell walls. As the rays continue to strike the organism, the swelling continues until the organism finally dies of internal explosion which bursts its outer skin or membrane.

UV-C PENETRATING CAPABILITIES

UV-C rays do not have great penetrating abilities into most substances. Obviously, in the case of air, it has a very effective killing range. Penetration is ineffective on “solid” surfaces. Consequently, Air and Surface Irradiation are principal functions of UV-C light. In addition, if you can see it, UV-C won’t kill it. Organisms of a size visible to the naked eye are usually too large and therefore too resistant to be killed by practical amounts of UV-C. Mold spores, for example, are very resistant to UV-C kill and it may take 10 to 100 times the intensity to kill them as compared to that of common bacteria because of the relative size difference between mold spores and bacteria.

UV “KILLING FACTORS” TO CONSIDER

The percentage of airborne organisms rendered non-viable depends among other factors:

- A The intensity of UV radiation.
- B The length of time of exposure to the UV radiation
- C The relative humidity
- D The air temperature
- E The microbial species

INVERSE SQUARE LAW

Like visible light, UV diminishes in intensity as the square of the distance from the UV source.

Example:

The intensity at 10 feet is $\frac{1}{4}$ the intensity at 5 feet.

PRIMARY BENEFITS OF UV-C VERSUS OTHER AIR PURIFICATION METHODS

1. UV-C is most effective against the very tiniest of airborne contaminants sizes most difficult to control with standard methods.
2. UV-C does not depend on a perfect air seal to be effective.
3. UV-C destroys rather than trapping airborne pathogens so there is not risk shaking loose contaminants during service.
4. UV-C does not degrade in the damp environments that are so often home to ductwork contaminants, as do media type filters.
5. UV-C leaves no residual chemical which could cause the “cure to be worse than the disease” in indoors environments.
6. Inexpensive to install, operate and maintain.
7. Easily tailored to the level of risk involved with out sacrificing control of smaller micro-organisms such as viruses.
8. UV-C can be used in conjunction with other types of air cleaning systems to tailor the level of protection to the risks involved.

UVF-1 Super

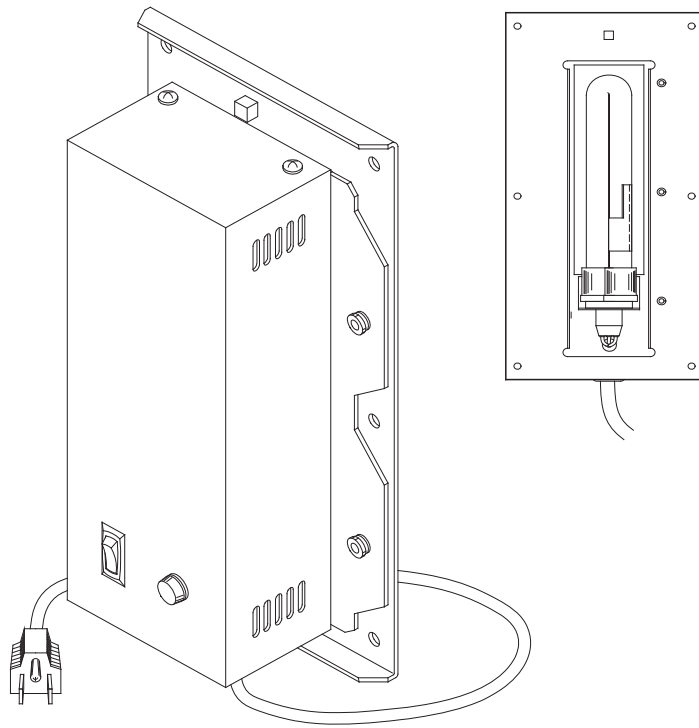

UVF-1 Super

These units are state-of-the-art air-purification systems for the purpose of controlling mold, odors and airborne bacteria. These advanced products utilize scientifically proven germicidal ultraviolet irradiation, which kills airborne bacteria and initiates a photolysis process which reacts on organics.

The dual band ultraviolet energy range produced by the TRI-MED UVF-1 units, mimics mother nature's use of the sun's energy for natural air purification. The UVF-1 Super units use TRI-MED's patented control system to insure the proper output for a given air volume.

Engineered and manufactured to the highest quality standards. Use of the UVF-1 units will drastically reduce common airborne concerns often plaguing the breathable air in the indoor environment.

TYPICAL DUCT MOUNTING

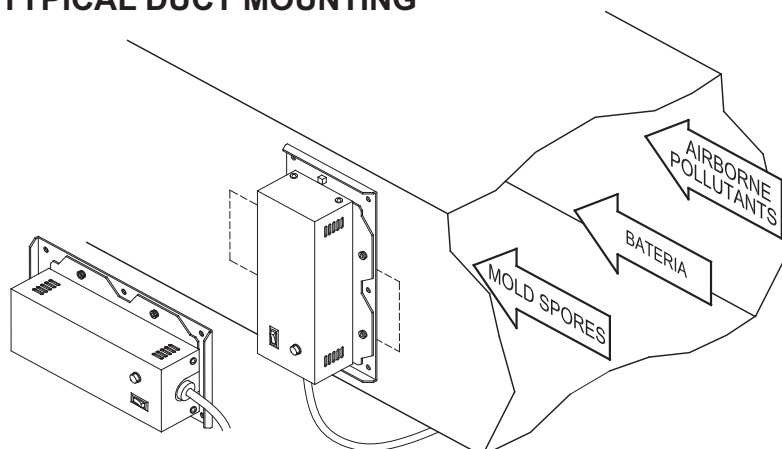

Function

Mold, Bacteria, Virus & Odor Control

Coverage

Up to 2900 sq. ft.

Mounting

Flange mounting for in-duct application

Physical Size

"H" = 9", "W" = 5 1/2", "D" = 3"

Weight

7 lbs.

Maintenance

As a result of advanced engineering, maintenance is minimal in dry or humid climates. An easy dusting off of the lamp occasionally is all that is required to keep the UVF-1 units performing at their maximum efficiency. Recommended lamp replacement is after 9,000 hours of continual operation.

Electrical

120V, 1 ph, 60 Hz

240V, 1 ph, 50 Hz (Export only)

Power consumption = 35W

Special Features

- Special "U" shape germicidal lamp, with ultra high output design utilizing a total of 12" lamp surface, emitting a broad range lengths from 185 to 254 nanometers. This allows for broad kill of airborne bacteria and control of mold and organic compounds.
- Special patented control system allows for output adjustment.
- TRI-MED's vectored lamp technology creates the largest killing zone in its product class.
- ETL Listed for Safety Assurance - # 538181

Other safety features

- Operation site glass to monitor lamp operation.
- Safety interlock switch to prevent any accidental exposure to the UV rays.
- Constructed or rugged 18 gauge steel.
- Long Lamp Life (kill effectiveness based on 9,000 hours).

Recommended Applications

Residential, Office, Marine, Light Commercial.

Examples include

Day care centres, nursing homes, trains, buses, ships, doctors' offices, schools, laboratories, veterinarian offices and restaurants.

The Source of Quality Air

Web-Site: www.airmedic.com • E-mail: trimed_airtex@engineered

by: **TRI-MED**
division of AIRTEX Manufacturing

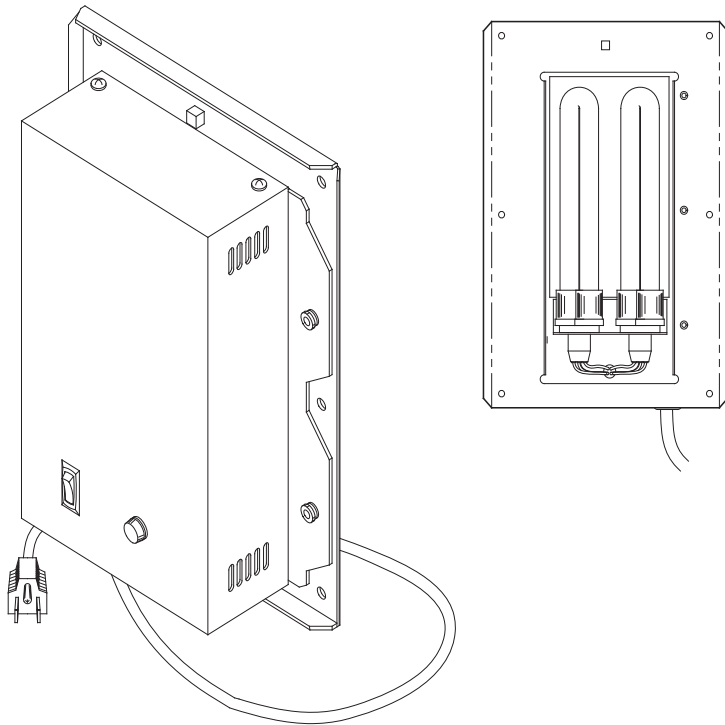

UVF-2

The UVF-2 is state-of-the-art air purification for the purpose of controlling virus and airborne bacteria. This advanced product utilizes scientifically proven germicidal ultraviolet irradiation, which kills airborne and initiates a photolysis process which reacts on organics.

The dual band ultraviolet energy range produced by the TRI-MED UVF-2 units, mimics mother nature's use of the sun's energy for natural air purification. The UVF-2 units use TRI-MED's patented control system to insure the proper output for a given air volume.

Engineered and manufactured to the highest quality standards. Use of the UVF-1 units will drastically reduce common airborne concerns often plaguing the breathable air in the indoor environment.

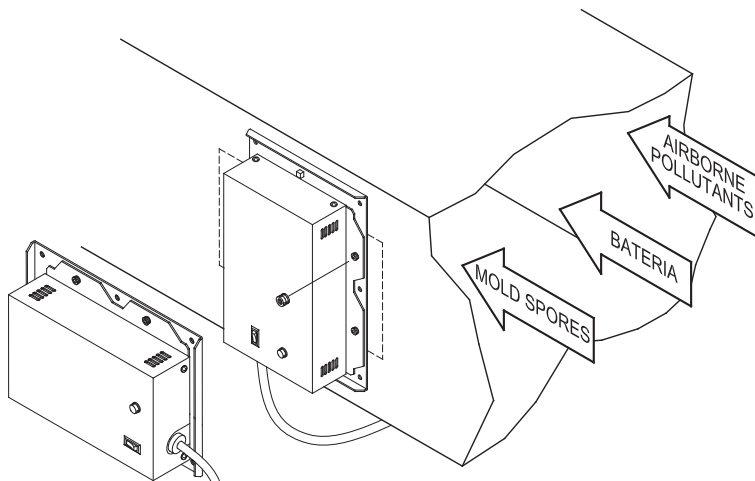

UVF-2

Function

Bacteria Control

Coverage

Indoor areas up to 2500 sq. ft. depending on air flow and load severity.

Mounting

Flange mounting for in-duct application

Physical Size

"H" = 9", "W" = 8 1/2", "D" = 3"

Weight

12 lbs.

Maintenance

As a result of advanced engineering, maintenance is minimal in dry or humid climates. An easy dusting off of the lamp occasionally is all that is required to keep the UVF-1 units performing at their maximum efficiency. Recommended lamp replacement is after 9,000 hours of continual operation.

Electrical

120V, 1 ph, 60 Hz
240V, 1 ph, 50 Hz (Export only)

Special Features

- Special "U" shape germicidal lamp, with ultra high output design utilizing a total of 24" lamp surface, emitting an ultraviolet wave length of 254 nanometers. This allows for maximum kill of airborne bacteria.
- TRI-MED's vectored lamp technology produces the largest killing zone in its product class.
- ETL Listed for Safety Assurance - # 538181

Other safety features

- Operation site glass to monitor lamp operation.
- Safety interlock switch to prevent any accidental exposure to the UV rays.
- Constructed or rugged 18 gauge steel.
- Extra long Lamp Life (kill effectiveness based on 9,000 hours).

Recommended Applications

Residential, Office, Marine, Light Commercial.

Examples include

Day care centres, nursing homes, trains, buses, ships, doctors' offices, schools, homes, laboratories, veterinarian offices and restaurants and many more.

The Source of Quality Air

Web-Site: www.airmedic.com • E-mail: trimed_airtex@engineered



division of AIRTEX Manufacturing

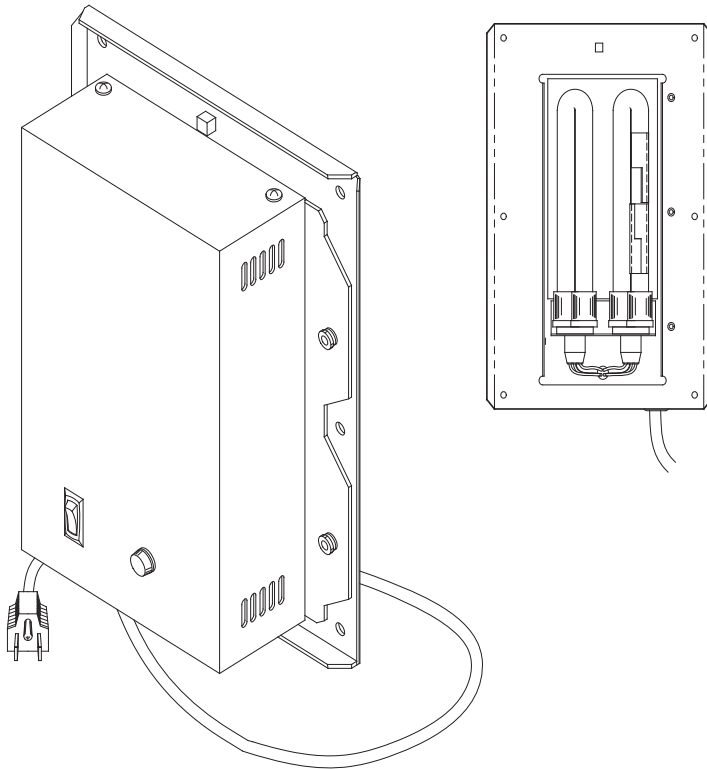

UVF-2 Plus & Super

Function

Mold, Bacteria, Virus & Odor Control

Coverage

UVF-2 Plus Up to 2900 sq. ft.

UVF-2 Super from 2401 to 4900 sq. ft.

Mounting

Flange mounting for in-duct application

Physical Size

"H" = 9", "W" = 8 1/2", "D" = 3"

Weight

12 lbs.

Maintenance

As a result of advanced engineering, maintenance is minimal in dry or humid climates. An easy dusting off of the lamp occasionally is all that is required to keep the UVF-2 units performing at their maximum efficiency. Recommended lamp replacement is after 9,000 hours of continual operation.

Electrical

120V, 1 ph, 60 Hz

240V, 1 ph, 50 Hz (Export only)

Special Features

- Special "U" shape germicidal lamp, with ultra high output design utilizing a total of 24" lamp surface, emitting a broad range of ultraviolet wave lengths from 185 to 254 nanometers. This allows for broad range kill of airborne bacteria and control of mold and organic compounds.
- Special patented control system allows for output adjustment during the life of the lamp.
- TRI-MED's vectored lamp technology creates the largest killing zone in its product class.
- ETL Listed for Safety Assurance - # 538181

Other safety features

- Operation site glass to monitor lamp operation.
- Safety interlock switch to prevent any accidental exposure to the UV rays.
- Constructed or rugged 18 gauge steel.
- Long Lamp Life (kill effectiveness based on 9,000 hours).

Recommended Applications

Residential, Office, Marine, Light Commercial.

Examples include

Day care centres, nursing homes, trains, buses, ships, doctors' offices, schools, laboratories, veterinarian offices and restaurants.

UVF-2 Plus and Super

These units are state-of-the-art air-purification systems for the purpose of controlling mold, odors and airborne bacteria. These advanced products utilizes scientifically proven germicidal ultraviolet irradiation, which kills airborne bacteria and initiates a photolysis process which reacts on organics.

The dual band ultraviolet energy range produced by the TRI-MED UVF-2 units, mimics mother nature's use of the sun's energy for natural air purification. The UVF-1 Super units use TRI-MED's patented control system to insure the proper output for a given air volume.

Engineered and manufactured to the highest quality standards. Use of the UVF-2 Plus or UVF-2 Super units will drastically reduce common airborne concerns often plaguing the breathable air in the indoor environment.

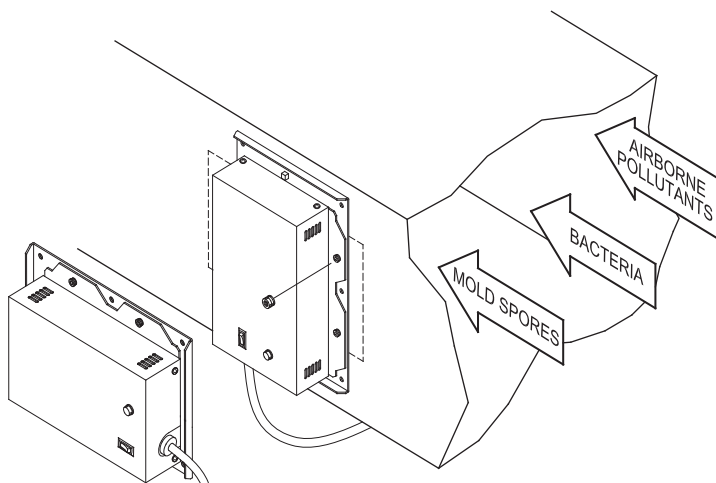

UVSHO-2

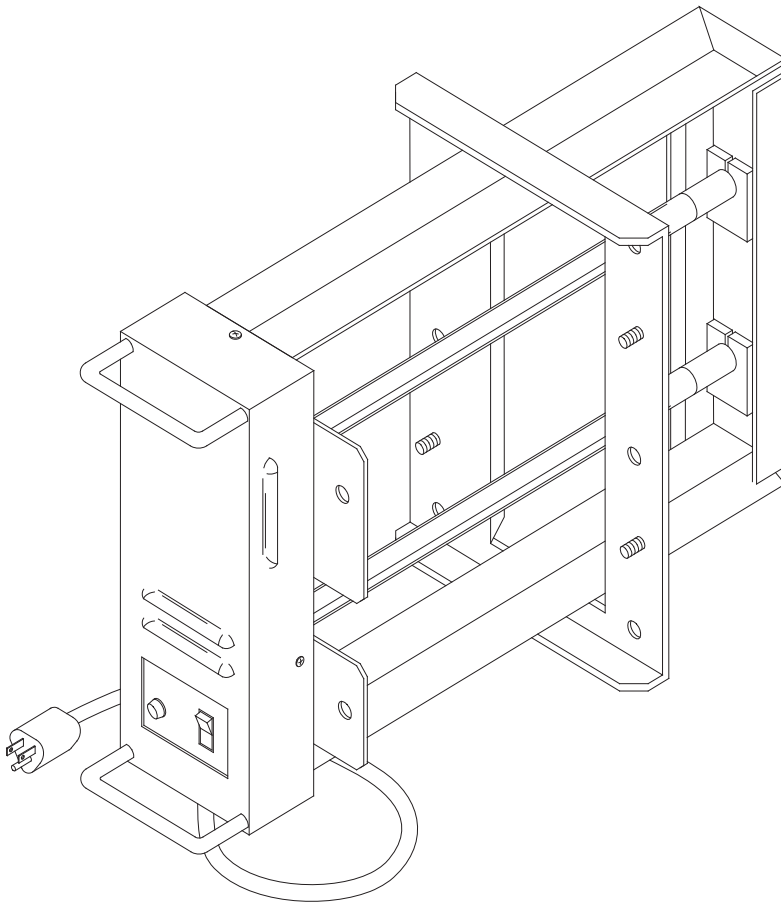

Function

Superior Bacteria and Virus Control

Coverage

13" x 18" Single unit

Mounting

In Duct cross-sectional area

Physical Size

"H" = 13", "W" = 8", "D" = 21"

Weight

19 lbs.

Maintenance

As a result of advanced engineering, maintenance is minimal in dry or humid climates. An easy dusting off of the lamp occasionally is all that is required to keep the UVSHO-2 units performing at their maximum efficiency. Recommended lamp replacement is after 9,000 hours of continual operation.

Electrical

120V, 1 ph, 60 Hz
 Amp draw = 1.28 Amps

Special Features

- Low cost to operation
- Highest output lamp in the industry
- Rugged 18 gauge Stainless Steel cabinet to eliminate lamp vibration
- Easy in-duct installation
- ETL listed
- Safety interlock switch to prevent any accidental exposure to the UV rays.
- Special interior coated lamps to extend lamp replacement to 9000 hrs. (effective kill based on 9000 hours).
- 6 ft. power cord for easy electrical connection

UVSHO-2

TRI MED's ultimate air purification device. This device contains two super high output UV-C lamps operating at a UV wavelength band that includes 254 nm. This advanced product utilizes scientifically proven germicidal irradiation to kill airborne bacteria. The unit inserts cross sectionally into the duct which forces pathogens across the main intensity zone (within a 6 inch radius of the lamp) for the most effective microorganism control device.

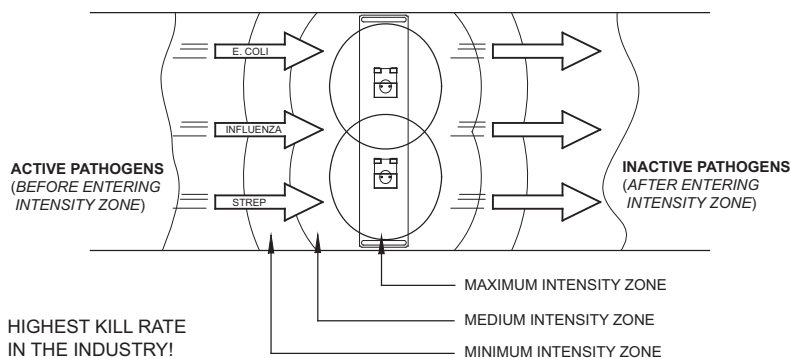

Recommended Applications

Residential, Office, Light Commercial.

Examples include

Day care centres, nursing homes, doctors' offices, schools, homes, laboratories, veterinarian offices and restaurants, kennels, live stock facilities, outpatient care centers, low immune health care protection and many more.

The Source of Quality Air

Web-Site: www.airmedic.com • E-mail: trimed_airtex@engineered



division of AIRTEX Manufacturing

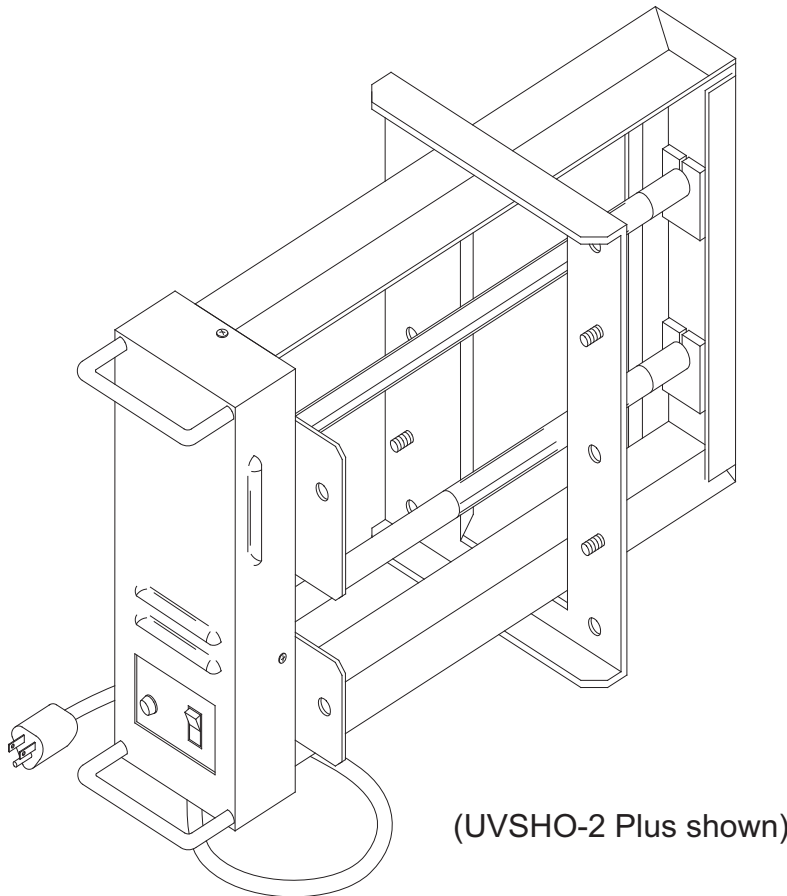

(UVSHO-2 Plus shown)

UVSHO-2 Plus and Super

TRI MED's ultimate air purification device. These device contains two super high output UV-C lamps operating at a UV wavelength band that include 185 and 254 nm. This advanced product utilizes scientifically proven germicidal irradiation to kill airborne bacteria and initiates a photolysis process which reacts on organics which include those generated by molds. The unit inserts cross sectionally into the duct which forces pathogens across the main kill zone (within a 6 inch radius of the lamp) for the most effective microorganism control device. The lower wavelength utilizes TRI MED's patented control system to guarantee proper oxidation levels for a given air volume.

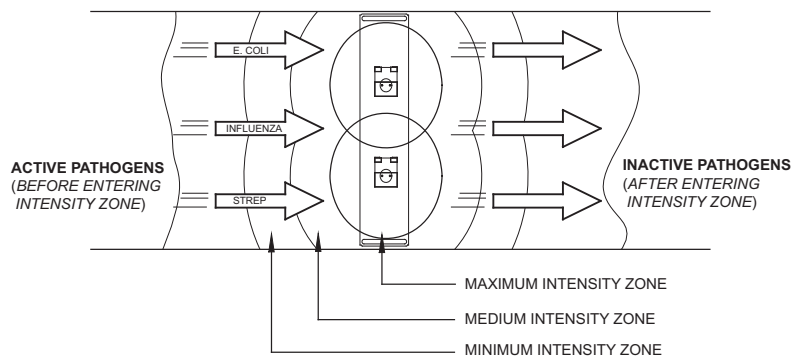

UVSHO-2 Plus & Super

Function

Superior Mold, Odor, Virus & Bacteria Control

Coverage

UVSHO-2 Plus from 5000 to 7500 CFM

UVSHO-2 Super from 7500 to 10500 CFM

13" x 18" Single unit

Mounting

In Duct cross-sectional area

Physical Size

"H" = 13", "W" = 8", "D" = 21"

Weight

19 lbs.

Maintenance

As a result of advanced engineering, maintenance is minimal in dry or humid climates. Easy dusting off of the lamp occasionally and all that is required to keep the UVF-2 unit performing at their maximum efficiency. Recommended lamp replacement is after 9,000 hours of continual operation.

Electrical

120V, 1 ph, 60 Hz

Amp draw = 1.28 amps

Special Features

- Low cost to operation
- Highest output lamp in the industry
- Rugged 18 gauge steel cabinet to eliminate lamp vibration
- Easy in-duct installation
- ETL listed
- Safety interlock switch to prevent any accidental UV exposure during maintenance
- 90° lamp intersection to air flow for maximum pathogen control
- Special interior coated lamps to extend lamp replacement to 9000 hrs. (effective kill based on 9000 hours).
- 6 ft. power cord for easy electrical connection

Recommended Applications

Residential, Office, Light Commercial.

Examples include

Day care centres, nursing homes, doctors' offices, schools, homes, laboratories, veterinarian offices and restaurants, kennels, live stock facilities, outpatient care centers, low immune health care protection and many more.

The Source of Quality Air

Web-Site: www.airmedic.com • E-mail: trimed_airtex@engineered

by: **TRI MED**
division of AIRTEX Manufacturing

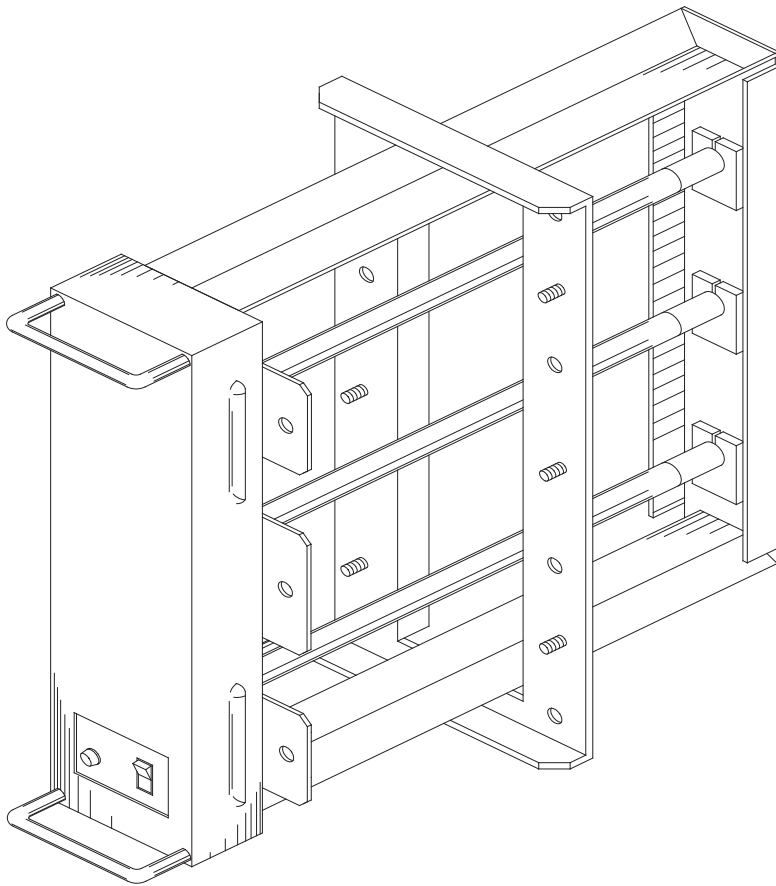

UVSHO-3

Function

Bacteria and Virus Control

Coverage

18" x 18" Single unit

Mounting

In Duct cross-sectional area

Physical Size

"H" = 18", "W" = 8", "D" = 21"

Weight

23 lbs.

Maintenance

As a result of advanced engineering, maintenance is minimal in dry or humid climates. An easy dusting off of the lamp occasionally is all that is required to keep the UVSHO-2 units performing at their maximum efficiency. Recommended lamp replacement is after 9,000 hours of continual operation.

Electrical

120V, 1 ph, 60 Hz
Amp draw = 1.77 Amps

Special Features

- Low cost, low energy consumption
- Highest output lamp in the industry
- Rugged 18 gauge Steel cabinet
- Compact size, easy in duct installation
- 90° lamp intersection to air flow for maximum pathogen control
- ETL listed
- Safety interlock switch to prevent any accidental exposure to the UV rays during maintenance
- Special interior coated lamps to extend lamp replacement to 9000 hrs. (effective kill based on 9000 hours).
- Optional 6 ft. power cord for quick connection

Recommended Applications

Residential, Office, Light Commercial.

Examples include

Schools, hospitals, veterinarian offices, kennels, livestock facilities, day care centers, nursing homes, outpatients care centres, low immune health care protection.

UVSHO-3

TRI MED's ultimate air purification device. This device contains three super high output UV-C lamps operating at a UV wavelength band that includes 254 nm. This advanced product utilizes scientifically proven germicidal irradiation to kill airborne bacteria. The unit inserts cross sectionally into the duct which forces pathogens across the main intensity zone (within a 6 inch radius of the lamp) for the most effective microorganism control device.

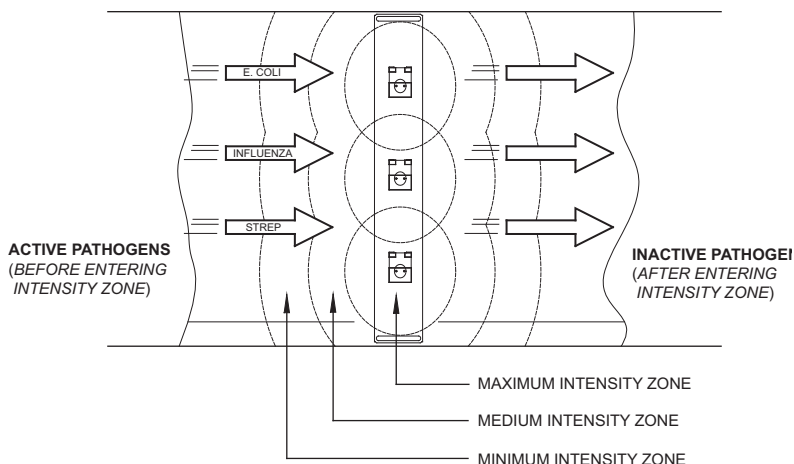

The Source of Quality Air

Web-Site: www.airmedic.com • E-mail: trimed_airtex@engineered



division of AIRTEX Manufacturing

UVSHO-3 Plus, Super and Max

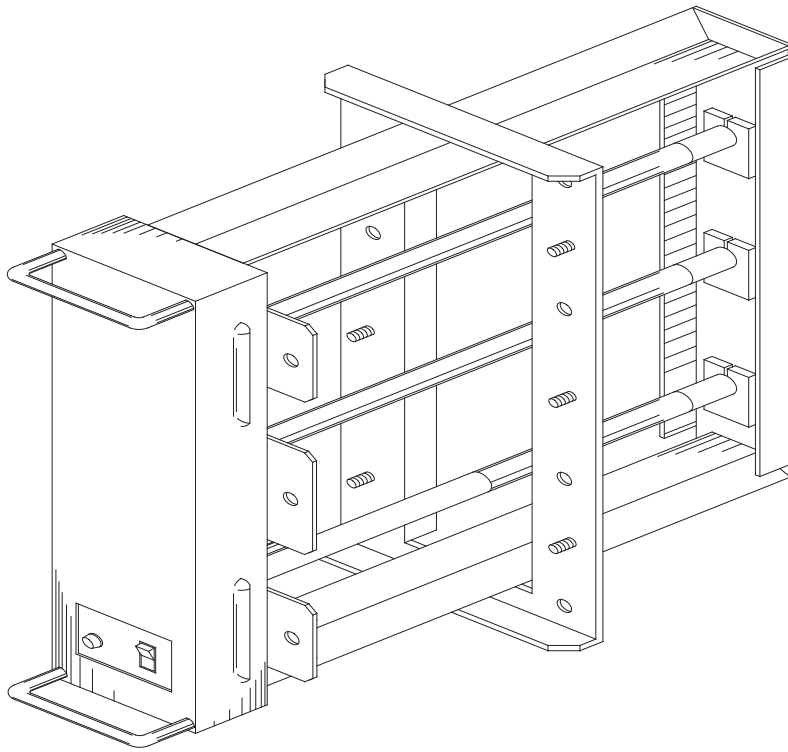

Function

Superior Mold, Odor, Virus & Bacteria Control

Coverage

UVSHO-3 Plus from 7500 to 10000 CFM
UVSHO-3 Super from 10001 to 12500 CFM
UVSHO-3 Max from 12501 to 15000
18" x 18" Single unit

Mounting

In Duct cross-sectional area

Physical Size

"H" = 18", "W" = 8", "D" = 21"

Weight

23 lbs.

Maintenance

As a result of advanced engineering, maintenance is minimal in dry or humid climates. An easy dusting of the lamp occasionally is all that is required to keep the UVF-2 units performing at their maximum efficiency. Recommended lamp replacement is after 9,000 hours of continual operation.

Electrical

120V, 1 ph, 60 Hz
Amp draw = 1.77 amps

Special Features

- Low cost to operation
- Highest output lamp in the industry
- Rugged 18 gauge steel cabinet to eliminate lamp vibration
- Easy in-duct installation
- ETL listed
- Safety interlock switch to prevent any accidental UV exposure during maintenance
- 90° lamp intersection to air flow for maximum pathogen control
- Special interior coated lamps to extend lamp replacement to 9000 hrs. (effective kill based on 9000 hours).
- Optional 6 ft. power cord for quick connection

Recommended Applications

Homes, schools, hospitals, veterinarian offices, kennels, livestock facilities, day care centres nursing homes, outpatients care centres, low immune health care protection.

UVSHO-3 Plus, Super and Max

TRI MED's ultimate air purification device. This device contains three super high output UV-C lamps operating at a UV wavelength band that include 185 and 254 nm. This advanced product utilizes scientifically proven germicidal irradiation to kill airborne bacteria and initiates a photolysis process which reacts on organics which include those generated by molds. The unit inserts cross sectionally into the duct which forces pathogens across the main kill zone (within a 6 inch radius of the lamp) for the most effective microorganism control device. The lower wavelength utilizes TRI MED's patented control system to guarantee proper oxidation levels for a given air volume.

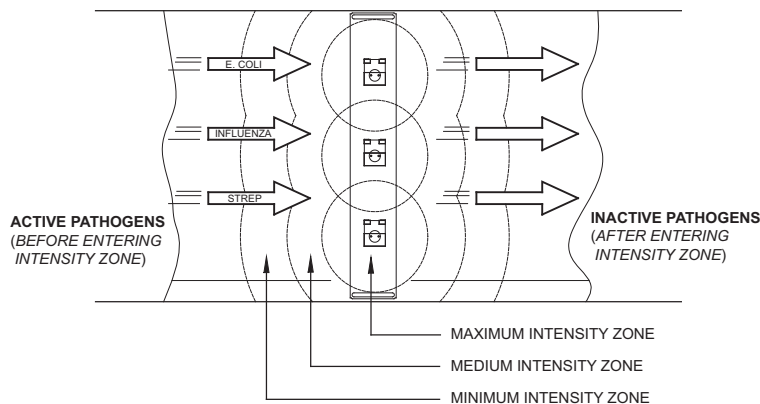

Ionization / Oxidation Spec

Odor Remover

General

Oxidation Equipment generator shall be used in the exhausted air section of the HVAC equipment. It shall reduce the odors from all hydrocarbon gases being removed from the facility using charged oxygen to attach itself to hydrocarbon gas molecules altering their structure to deodorize the compound.

Oxidation Equipment

- Oxidizer units shall be compact, self-contained units, with all components factory mounted to maximize the HVAC system's air flow.
- The means of charging oxygen shall be by corona discharge principle, which shall convert oxygen in the air stream to form ozone. The corona discharge plates shall be held between two electric fields so as to form uniform corona discharge. No other system shall be used.
- Each Generator head shall be provided with six (6) dual sided corona discharge plates. All the corona discharge plates shall be housed in stainless steel enclosures and mounted on a rack assembly. Care should be taken to ensure the generator is mounted where there is a steady flow of air.
- Components in contact with air stream shall be enclosed in stainless steel casing, with sufficient openings to allow adequate flow of air over the corona discharge plates.
- Generator heads holding the corona discharge elements shall be fabricated out of stainless steel that naturally minimizes deposits of contaminants, on the electrical contacts and the plate support and shall be classified as "hazardous duty heads".
- The generators shall be suitable for mounting in an air velocity up to 1500 ft/min.
- The generators shall be suitable for airflow in either direction.
- Generators shall be interlocked with the motor exhaust fan. This will prevent start of the generators unless fan motor is energized.
- The generators shall not require any consumables for its operation, except for use of electricity.
- The system shall not rely on initial or replacement of filters of any sort to remove odors and chemicals.
- The generator heads will be placed in an accessible compartment to allow access for plate cleaning.
- Generator shall be provided with an external remote mounted regulator that shall allow regulation of output of ozone from 0 to 100% of the rated output in at least 8 steps. It shall be complete with ON/OFF switch and pilot light mounted in the electrical control panel of the HVAC system.
- Only a single source of electric power shall be necessary to operate the generator. Electrical source shall be 110 volts, single phase. The unit shall be properly grounded. Ease of maintenance is extremely important consideration. The generators shall be manufactured to permit very easy withdrawals and refitting of the corona plates.

The Source of Quality Air



division of AIRTEX Manufacturing

Web-Site: www.airmedic.com • E-mail: trimed_airtex@engineered

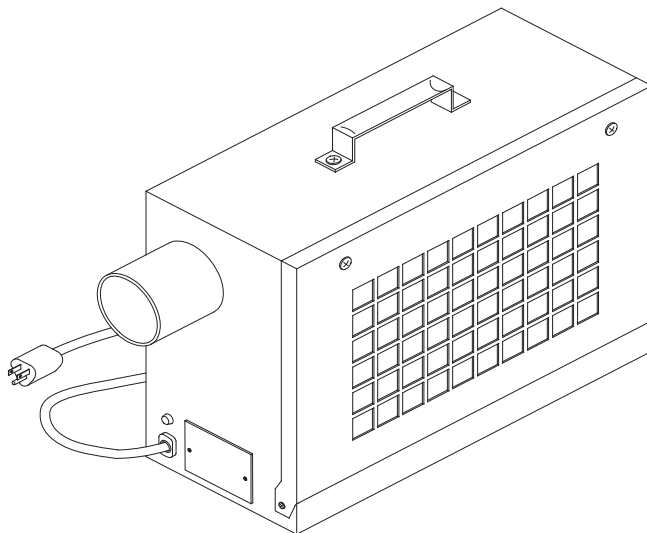

SI-200 & SI-500 Plus, Super and Max

Function

Control of odors, VOC's and mold

Coverage

SI-200 from 500 to 5000 CFM
SI-500 from 1500 to 10000 CFM

Mounting

Duct attachable or portable

Control

Manual (standard on board) or
Automatic Remote (optional)

Electrical

120V, 1 ph, 60 Hz
240V, 1 ph, 50/60 Hz (export only)

Physical Size

"H" = 14", "W" = 9 1/4", "L" = 18 3/4"

Weight

25 lbs.

Special Features

- 135 CFM Blower delivers high concentrations of ozone for source application
- 2 or 5 high efficient double screen discharge plates
- 2 ply poly pad filter for maximum plate protection against particulates, extending maintenance intervals
- On-Board fan and ozone output controls
- Rugged 18 gauge construction
- 3" air discharge outlet for maximum grams of usable trivalent oxygen

The SI-200 & SI-500 are self-contained air purification products designed to reduce potentially high concentrations of odors and VOC's. They are a very economical solutions, using minimal power consumption and requiring no additional chemicals or high priced media for operation.

The Oxidizer process is simple: Using the basic principles of organic chemistry, ozone (oxidant) is used as the stimulus to naturally breakdown (oxidize) gaseous compounds, producing CO₂, H₂O and O₂ as the primary end products.

For maximum results, the SI-200 & SI-500 units should be connected to the suction side of any ducted system ot maximize contact time between the oxidant and odorous gases and achieve complete oxidation.

These units are easily adaptable to the A-TAC system to create an automated air purification system, continually balancing oxidant levels with load levels for the cleanest air.

The SI-200 and SI-500 units will treat air problems in spaces where there is no existing air ducts* or can be used to inject ozone into ducted air systems.

Typical Effected Gases Include: Formaldehyde, Xylene, Toluene, Styrene, Glutaraldehyde, Carbon Monoxide, Acetone, Benzene, Hydrogen sulfide, Ammonia, Ketone, Complex ETS gases (environmental tobacco smoke) and general food odors. (for complete list, contact factory).

* Recommend use with A-TA system if used in occupied space.

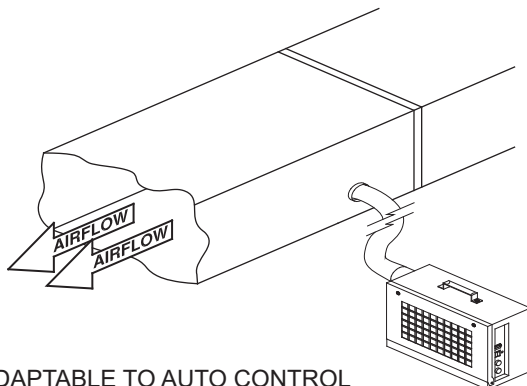

ADAPTABLE TO AUTO CONTROL

TRI-MED				
OXIDIZER MODEL	FAN CONTROL	OXIDIZER BLOWER SIZE	DISCHARGE OPENING	DELIVERED OZONE *
SI-200	0-100%	140 CFM	3"	0.7 ppm
SI-500	0-100%	140 CFM	3"	1.6 ppm

* This is measured ozone levels after discharge of the unit and at maximum air volume.
This is not a projected output before system loses.
Ozone production can vary depending on ambient conditions.

The Source of Quality Air

Web-Site: www.airmedic.com • E-mail: trimed_airtex@engineered

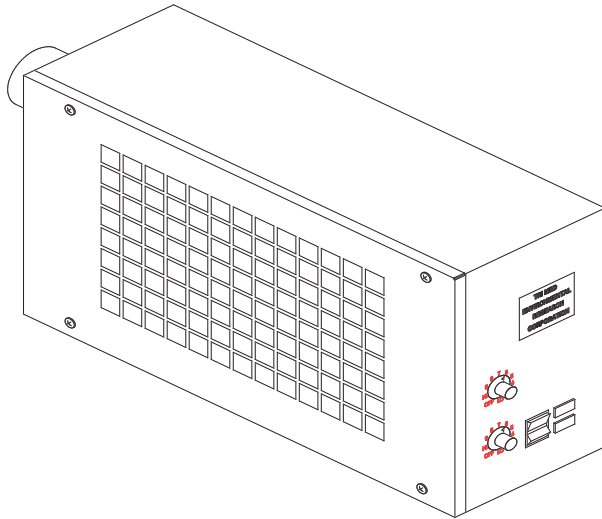

SI-1000 & SI-1000 Max

Function

Control of odors, VOC's and mold

Coverage

SI-1000 from 3500 to 25000 CFM
 SI-1000 Max from 10500 to 35000 CFM
 (Actual sizing depends on load conditions)

Mounting

Duct attachable or portable

Control

Manual (standard on board)
 Automatic Remote (optional)

Electrical

120V, 1 ph, 60 Hz
 240V, 1 ph, 50/60 Hz (export only)

Physical Size

"H" = 14", "W" = 9 1/4", "L" = 23"

Weight

SI-1000 35 lbs.
 SI-1000 Max 50 lbs.

Special Features

- 180 CFM Blower delivers high concentrations of ozone for source application
- 10 high efficient double screen discharge plates
- 2 ply poly pad filter for maximum plate protection against particulates, extending maintenance intervals
- On-Board fan and ozone output controls
- Rugged 18 gauge Stainless Steel construction
- 3" air discharge outlet for maximum grams of usable trivalent oxygen
- Hour meter for easy maintenance tracking

The SI-1000 & SI-1000 MAX are self-contained air purification products designed to reduce potentially high concentrations of odors and VOC's. They are a very economical solutions, using minimal power consumption and requiring no additional chemicals or high priced media for operation.

The Oxidizer process is simple: Using the basic principles of organic chemistry, ozone (oxidant) is used as the stimulus to naturally breakdown (oxidize) gaseous compounds, producing CO₂, H₂O and O₂ as the primary end products.

For maximum results, the SI-1000 & SI-1000 MAX units should be connected to the suction side of any ducted system to maximize contact time between the oxidant and odorous gases and achieve complete oxidation.

These units are easily adaptable to the A-TAC system to create an automated air purification system, continually balancing oxidant levels with load levels for the cleanest air.

The SI-1000 and SI-1000 MAX units will treat air problems in spaces where there is no existing air ducts* or can be used to inject ozone into ducted air systems.

Typical Effected Gases Include: Formaldehyde, Xylene, Toluene, Styrene, Glutaraldehyde, Carbon Monoxide, Acetone, Benzene, Hydrogen sulfide, Ammonia, Ketone, Complex ETS gases (environmental tobacco smoke) and general food odors. (for complete list, contact factory).

* Recommend use with A-TA system if used in occupied space.

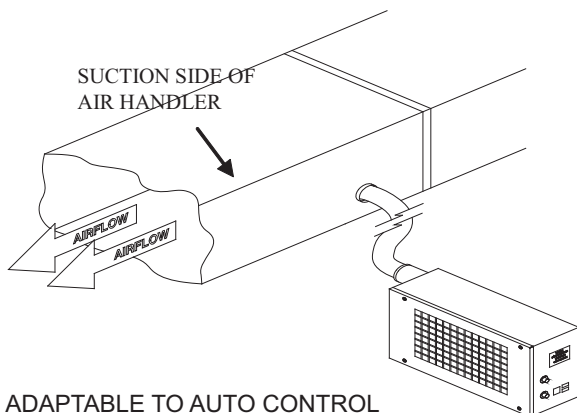

TRI-MED				
OXIDIZER MODEL	FAN CONTROL	OXIDIZER BLOWER SIZE	DISCHARGE OPENING	DELIVERED OZONE *
SI-1000	0-100%	180 CFM	3"	3.0 ppm
SI-1000 MAX	0-100%	180 CFM	3"	6.8 ppm

* This ozone levels are measured in a test air stream where there are no challenges to consume the energized oxygen which would occur in a contaminated air stream under typical applications. The air tested was at the exact discharge. This ozone as measured would then be diluted in the injected air stream as a ratio to the total air volume. It is not the intent to produce ozone, but to activate oxygen for oxidation. TRI MED offers load controllers and high limit devices to ensure the systems safety and effectiveness.

ADAPTABLE TO AUTO CONTROL
 TM0708

The Source of Quality Air

Web-Site: www.airmedic.com • E-mail: trimed_airtex@engineered



division of AIRTEX Manufacturing

SI-2000 & SI-2000 Max

Function

Control of severe odors, and mold

Coverage*

SI-2000 from 5000 to 15000 CFM
 SI-2000 Max from 15001 to 25000 CFM
 (Actual sizing depends on load conditions)

Mounting

Wall or HVAC unit mounted

Control

Local fan and ozone controls
 Optional Automatic Remote (A-TAC):
 • TM-L, • TM3-AR, • TM3-ARL

Electrical

120V, 1 ph, 60 Hz

Physical Size

"H" = 33", "W" = 46", "L" = 15"

Weight

SI-2000 35 lbs.
 SI-2000 Max 50 lbs.

Special Features

- High efficiency variable speed, squirrel cage blower
- Hinged doors with lever-lock handle for easy access to filter, generator head, control and blower / electrical connection sections
- 30% filtration
- 4" discharge nozzles 150 CFM
- Rugged 18 gauge Stainless Steel construction
- 0-100% on board output control w/ remote switch
- Built in hour meter for proper maintenance scheduling
- Weather-tight enclosure for continuous outdoor use.
- SI-2000 Std. is equipped with (20) 3.5" x 3.5" x 0.035 mil corona plates
- SI-2000 Max. is equipped with (12) 5" x 7" x 0.04 mil corona plates

These Industrial Duty Units are self-contained air purification products designed to reduce high concentrations of odors. They are a very economical solution, using minimal power and requiring no chemical additives or high priced media for operation.

The Oxidizer process is simple: Using the basic principles of organic chemistry, where charge oxygen (oxidant) is used as the stimulus to naturally breakdown or change molecular structure (oxidize) of gaseous compounds, leaving non-odorous base compounds.

For maximum results, the SI-2000 & SI-2000 MAX units should be connected to the suction side of any air moving system to inject the charged oxygen into the controlled odorous air flow permitting the use of duct work to create a contact zone between the oxidant and odorous gases to achieve oxidation.

These units are easily adaptable to the A-TAC system to create an automated air purification system, continually balancing oxidant levels with load levels for the cleanest air and minimal energy consumption.

The SI series units can be used in source capture applications like cooking, exhaust or can be used to inject ozone into ducted air systems.

Typical Effected Gases Include: Formaldehyde, Xylene, Toluene, Styrene, Glutaraldehyde, Carbon Monoxide, Acetone, Benzene, **Hydrogen sulfide, **Ammonia, Ketone, Complex ETS gases (environmental tobacco smoke) and general food odors. (for complete list, contact factory).

** Odors from these compounds are neutralized by adding oxygen to the existing compounds.

TRI-MED		
OXIDIZER MODEL	# GEN HEADS	CURRENT DRAW
SI-2000 STD	2	4.1 amps
SI-2000 MAX	2 HO	5.7 amps

