

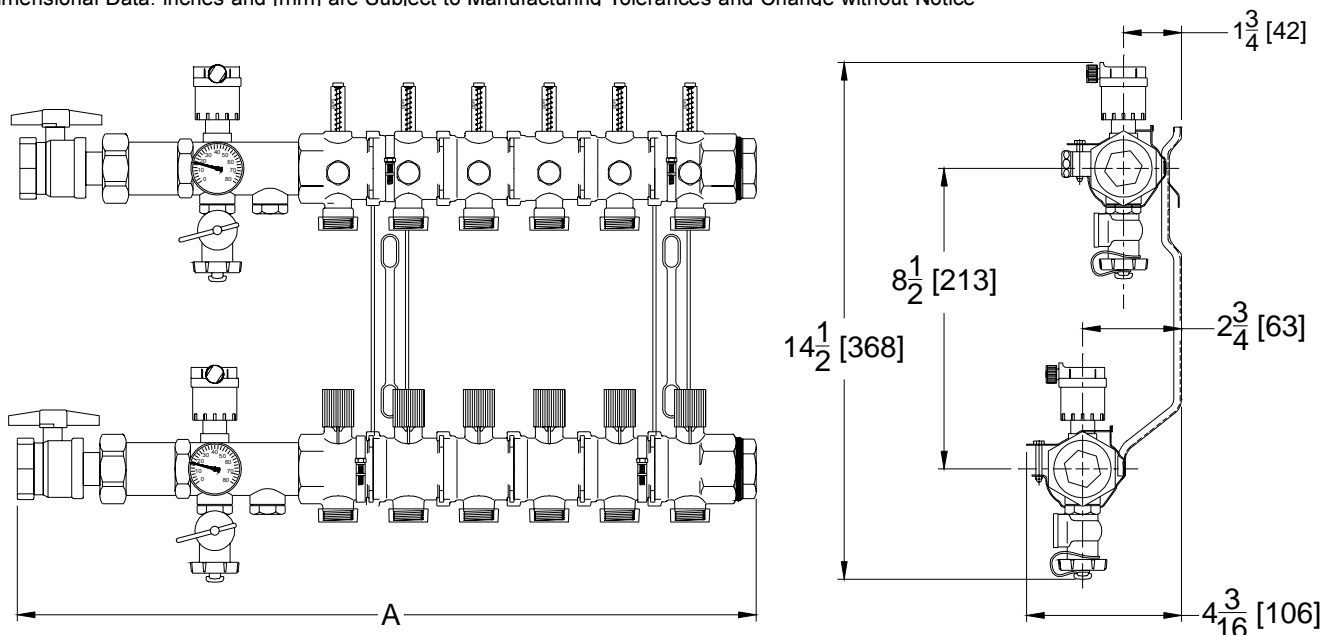

QickZone Modular Brass Manifold System with Thermometers

TAG _____

Dimensional Data: inches and [mm] are Subject to Manufacturing Tolerances and Change without Notice



ENGINEERING SPECIFICATION: Qest Hydronics QickZone 1-1/4" diameter modular brass manifold system with thermometers, allowing for combinations of 2 to 12 loops per manifold. System is rated at a maximum working pressure of 150 PSI, and a maximum temperature of 230 °F. Each supply section shall have an integral flow meter, circuit balancing valve, and positive shut off valve. Flow meters shall have the ability to be adjusted from 0.132 to 1.32 gpm. Each return section shall have mounting capabilities for either a manual stop valve or a zone actuator capable of individual loop control. Supply and return sections able to connect with 3/8", 1/2", 5/8" and 3/4" QESTPEX tubing. Complete with supply sections, return sections, ball valves, automatic air vents, hose bibs, thermometers and mounting brackets.

Part Number	Description	'A' Dimension Loops Per Manifold	12-1/4	14-1/4	16-1/4	18-1/4	20-1/4	22-1/4	24-1/4	26-1/4	28-1/4	30-1/4	32-1/4
			[311]	[362]	[413]	[464]	[514]	[565]	[616]	[667]	[718]	[768]	[819]
QHMC	QickZone Manifold Supply/Return Modules		02	03	04	05	06	07	08	09	10	11	12
QHMKIT	QickZone Manifold Assembly Kit			1	2	3	4	5	6	7	8	9	10
QHMAVKIT1	QickZone Manifold Air Vent Assembly Kit #1							Qty (1) Needed					

QHMKIT QickZone Manifold Assembly Kit Includes

Qty	Part Number	Description
1	QHMODAK	Adjustment Key
1	QKLABELS	Labels
1	QHMODMB	Pair of Manifold Brackets
1	QHREM	Return Endpiece Modules
1	QHSEM	Supply Endpiece Modules
1	QHMBV66R	1-1/4" Ball Valve w/Red Handle and Tailpiece
1	QHMBV66B	1-1/4" Ball Valve w/Blue Handle and Tailpiece

QHMC QickZone Manifold Supply /Return Modules

Qty	Part Number	Description
1	QHRCM	Return Central Module
1	QHSCM	Supply Central Module

QHMAVKIT QickZone Manifold Air Vent Assembly Kit#1

Qty	Part Number	Description
1	QHMAVKIT1	Self Sealing Assembly w/Air Vent Drain Valve (U.S. Hose Bibb) and Thermometers

ACCESSORIES:

___ QHMMC2	QickZone Manifold Connection Fitting - 3/8"	___ QHSTT3	3-Position Setback Thermostat with Timer
___ QHMMC3	QickZone Manifold Connection Fitting - 1/2"	___ QHMBMVDS	4 Wire Zone Valve Actuator
___ QHMMCJ	QickZone Manifold Connection Fitting - 5/8"	___ QHBMO	4-Wire Zone Valve Motor
___ QHMMC4	QickZone Manifold Connection Fitting - 3/4"	___ QHDP	24V DC Double Pole Dbl Throw Pump Relay
___ QHZC	Multi-Zone Control Center	___ QHDPAC	24V AC Pump Relay
___ QHST	Standard Thermostat	___ QHTPR	24V DC Triple Pole Double Throw Pump Relay
___ QHST3	3-Position Setback Thermostat	___ QHBT	120V/24V 40 VA 50/60 Cycle Transformer

*Manifold Connection Fittings Required
 **Approximate Manifold Length

REV. C	DATE: 06/08/01	C.N.NO. 88148
DWG. NO. 66330	PROD. NO. QHMBMT	