



Ultra High Efficiency Space Heating and Water Heating

**The only 97% efficient, load
matched, modulating combination
space heating and water heating
stainless steel tank type unit on
the market!**



Ultra High Efficiency Space Heating and Water Heating at 97% efficiency (Residential or Commercial)

A Holistic Approach to Comfort Systems and Domestic Water Heating

In an effort to provide a holistic approach to the space heating & cooling as well as the water heating requirements of residential and commercial structures, we have married three proven technologies to create the Phoenix. They are digital controls, true burner modulation, and condensing flue gas efficiency. The result is tank type "water heater" that is approved for space heating and water heating systems utilizing ducted heating and cooling systems, radiant floor, solar assisted, or dual fuel systems or any combination of these.

All other conventional and high efficiency water heaters, on the market today, are of a fixed input design. That means the burner fires at full capacity no matter what the water heating load is at the time. This can result in wasteful, and expensive fuel consumption. The Phoenix is the only water heating appliance of its kind that is equipped with a fully modulating burner that responds in direct proportion to the water heating requirement at any time. It is as if your integrated water heating and space heating system is on "cruise control". The Phoenix is truly a load matching appliance; it never burns more fuel than is necessary to meet the need whether in heating or water heating mode providing you maximum fuel efficiency and very low operating cost.

The Phoenix can be sized to handle almost any year round domestic water heating requirement while simultaneously responding to the space heating in the winter all at 97% efficiency while occupying a minimum of space.

The Phoenix Solar has all the attributes of the standard Phoenix plus an added high efficient heat exchanger for maximum transfer of the solar energy produced by solar panels (supplied by others). The Phoenix Solar is an integrated supplemental or back up solution in a solar heating application all in one unit.



Ultra High Efficiency Space Heating and Water Heating at 97% efficiency (Residential or Commercial)

Here is how it works!

Space Heating:

When the room thermostat for a heating zone calls for heat, a pump circulates hot water from the Phoenix to the heat emitting device. A portion of the heat is given up to the space as the water passes through the heat emitter. For example, when using an air handler with a hot water coil as the heat emitter, the water is about 140F entering the hot water coil. The air handler blower passes air through the hot water coil where the air is heated for distribution via the duct system to the space to be heated. This process drops the water temperature about 20 degrees. The discharge air temperature to the space is between 105—115F. The water continues circulation to return to the Phoenix at approximately 120F. The Phoenix burner control senses the 20 degree drop in temperature and fires the burner, but only at a BTU burn rate sufficient to 'recover' the 20 degrees used to heat the space.

Since the pump circulating the water to each hot water coil in the air handler, moves only 3 to 6 gallons/minute of hot water, and the average call for heat is only about 10 minutes at a time, the Phoenix only has to recover the BTUs given up in 30 to 60 gallons with a 20 degree loss of heat. Because of the 96% efficiency built into every Phoenix, the smallest Phoenix can recover 20 degrees at the rate of 8 gallons per minute, while the largest Phoenix will recover 20 degrees at the rate of 18 gallons per minute. In both examples, the burner firing rate is no more than what is required to match the load resulting in extremely low fuel consumption at maximum efficiency!

The same process, but generally at a lower water temperature, is carried out for radiant floor applications. In any case, the Phoenix firing rate is always 'matching the load'.



Ultra High Efficiency Space Heating and Water Heating at 97% efficiency (Residential or Commercial)

Here is how it works!

Domestic Water Heating:

Earlier, in the discussion of how the space heating works, you learned that the Phoenix can recover almost instantly to a space heating load. Now, let's look at domestic water heating.

If a domestic hot water draw occurs, such as someone showering, or washing dishes, the hot water stored in the tank discharges through the domestic hot water plumbing serving the shower or dish washer. The burner controls sense there is an increased drop in temperature in the tank and the burner increases the firing rate commensurate with the combined space heating load, and the domestic hot water draw. When either load is satisfied, the burner modulates back to an input commensurate with that required by the current need. When all 'loads' are satisfied, the Phoenix turns the burner off as soon as the tank 'set point' temperature has been reached. The Phoenix is off and now in 'standby' waiting for the next call for heat.

If there is a large garden tub that requires filling, the Phoenix can handle that assignment too. The Phoenix is available in 55 gallon, 80 gallon, or 119 gallon tank sizes. If your tub requires 100 gallons of hot water for a good soaking, you will draw a mixture of hot and cold water to achieve the desired tub temperature. If the water is stored in the Phoenix at 140F, and the tub is filled with 100F water, only 55% of the stored hot water will be required if the incoming cold water is 50F. To fill the 100 gallon tub, an 80 gallon Phoenix will be required to fill the tub in one draw. The length of time required to recover that amount of hot water will be dictated by the Phoenix BTU input. A PH130-80, for example, will recover in approximately 11 minutes. So, even in this situation there is enough reserve capacity to continue heating the space.



Ultra High Efficiency Space Heating and Water Heating at 97% efficiency (Residential or Commercial)

Features:

- Approved Combination Space Heating and Water Heating Device under ANSI Z 21.10.3.
- Ultra quiet, fully modulating burner providing precisely the right BTU input at 97% efficiency across the range of modulation to match the heating load.
- Bottom flue outlet means zero standby flue loss.
- Vinyl jacket over 2—3 " foam insulation over a 316L stainless steel tank for long life and negligible standby loss.
- 800H/Cupronickel Heat Exchanger for maximum corrosion resistance in a condensing appliance.
- Silent burner operation with reliable spark ignition.
- PVC Venting with multiple termination options for exhaust and combustion air (no special combustion air louvers, or ducting and no chimney or B-Vent required).
- Zero clearance to combustibles for the Phoenix unit and PVC vent system.
- 4 stainless steel side tank tapings (2 domestic and 2 space heating) standard equipment.
- State of the art user friendly digital control system with LED readout, and low water cutoff.
- Easy Installation and Service.
- Field convertible to LPG or Natural Gas using factory supplied conversion kit.
- Air handlers & Phoenix requires only 120/60/1 lighting circuit electrical connections.



Ultra High Efficiency Space Heating
and Water Heating at 97% efficiency
(Residential or Commercial)

Typical Combination Space Heating and Water Heating System

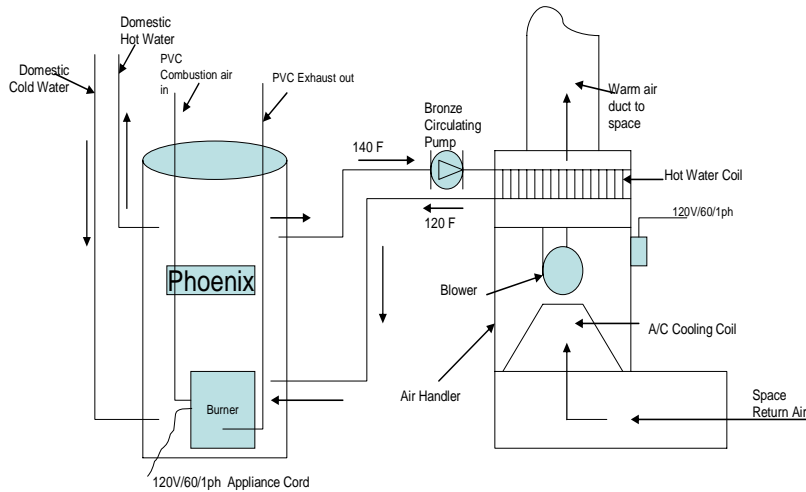

Note: System shown with air handler with integral hot water coil, pump relay and blower relay circuit.

Use the Phoenix for ultra high efficiency in
combination single or multi-zone **ducted**
heating and cooling systems, while producing
copious amounts of domestic hot water at 97%
efficiency!



**Ultra High Efficiency Space Heating
and Water Heating at 97% efficiency
(Residential or Commercial)**

**Typical Combination Space Heating and Water Heating
System W/ Solar Assist & Radiant Floor**

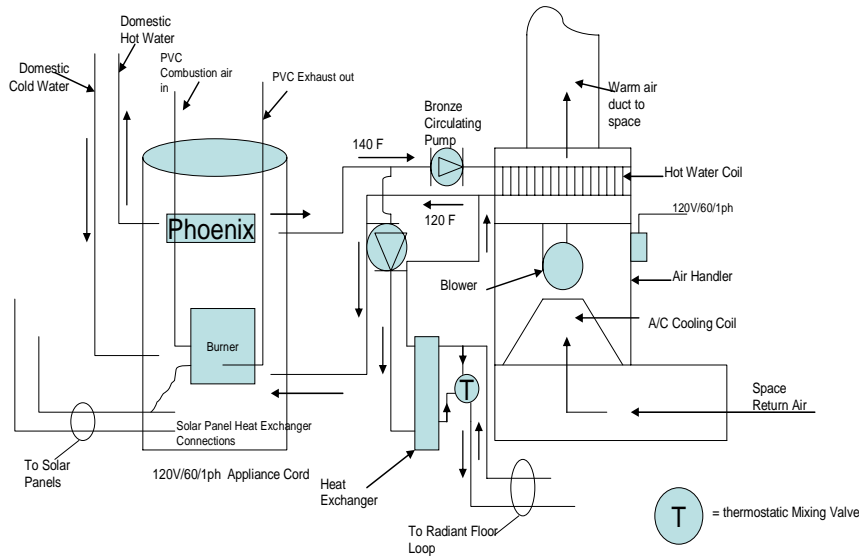

Note: System shown with air handler with integral hot water coil, pump relay and blower relay circuit.

Use the Phoenix for ultra high efficiency in combination multi-zone ducted heating and cooling systems, and radiant floor heating, while producing copious amounts of domestic hot water at 97% efficiency !



Ultra High Efficiency Space Heating and Water Heating at 97% efficiency (Residential or Commercial)

Typical Combination Space Heating and Water Heating System W/Dual Fuel

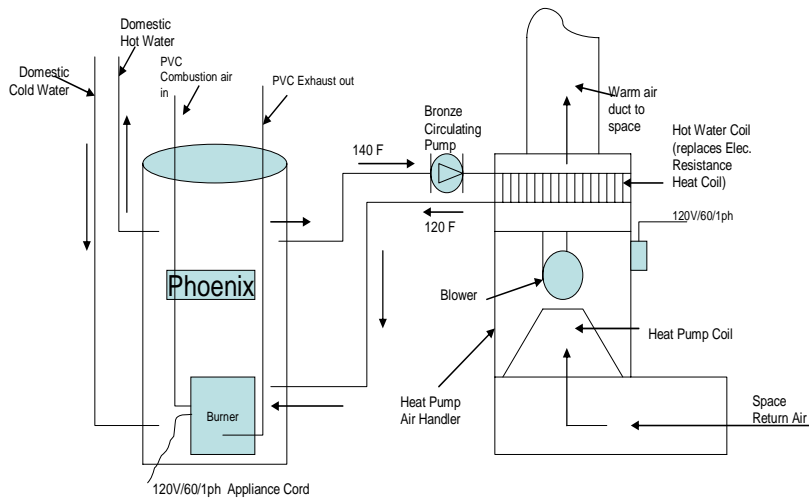

Note: System shown with air handler with integral hot water coil, pump relay and blower relay circuit.

Use the Phoenix for ultra high efficiency for **supplemental and/or an emergency heat source with Heat Pump** ducted heating and cooling systems while producing copious amounts of domestic hot water at 97% efficiency !



Ultra High Efficiency Space Heating and Water Heating at 97% efficiency (Residential or Commercial)

Typical Combination Space Heating and Water Heating System W/Dual Fuel

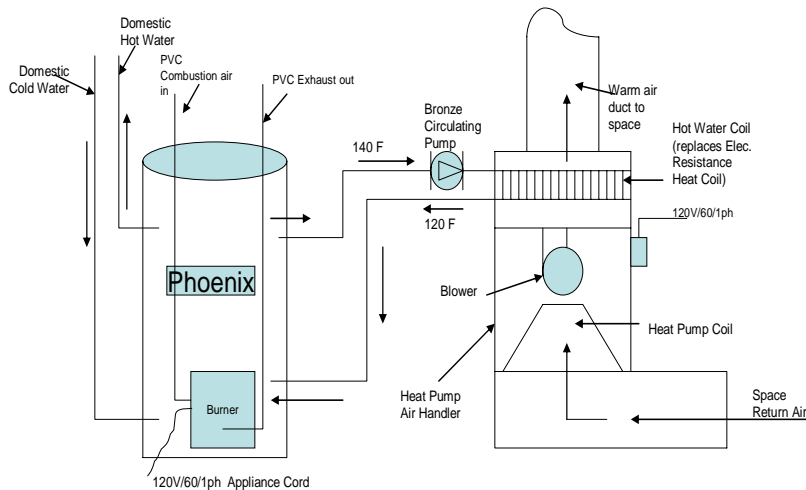

Note: System shown with air handler with integral hot water coil, pump relay and blower relay circuit.

Use the Phoenix for ultra high efficiency to **eliminate the high cost of operation associated with the standard installed electric resistance supplemental/ emergency heating element used in Heat Pump** (works great as a primary heating device if the heat pump is inoperative!) ducted heating and cooling systems while producing copious amounts of domestic hot water at 97% efficiency !



**Ultra High Efficiency Space Heating
and Water Heating at 97% efficiency
(Residential or Commercial)**

Solar Combo System

**Typical Combination Space Heating and
Water Heating System W/ Solar Assist**

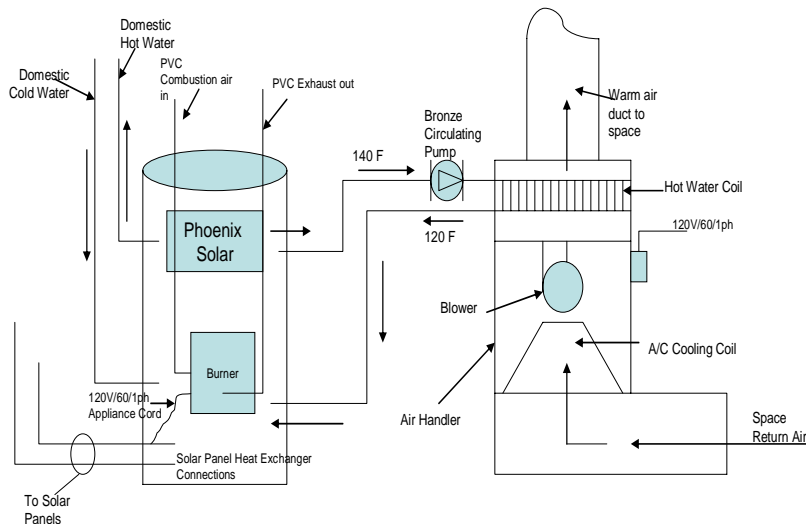

Note: System shown with air handler with integral hot water coil, pump relay and blower relay circuit.

**Use the 80 or 119 gallon Phoenix Solar for a 97% efficient
source to supplement and/or back up to your solar space
heating and/or water heating! system!**



Ultra High Efficiency Space Heating
and Water Heating at 97% efficiency
(Residential or Commercial)

Phoenix Combo System Sizing/Selection Estimator



COMBINED HYDRONIC SYSTEMS

SIZING ESTIMATOR

STEP 1 SIZING COMBINED HYDRONIC BTU/HR REQUIREMENTS

(A) Determine btu heating requirement units using Manual J or other methodology.



For locations with altitudes over 7,000 feet, use Zone 1. Determine from the map which zone you are in. Multiply the home's heat loss by the following:

- In Zone 1, multiply by 1.43
- In Zone 2, multiply by 1.30
- In Zone 3, multiply by 1.20

The resultant is the minimum water heater Btu/h output necessary for adequate water heating and space heating.

STEP 2 DETERMINE STORAGE REQUIREMENTS*

| (A) | Number of Bathrooms | Number of People | | | |
|-----|---------------------|------------------|-----|-----|-----|
| | | 1-2 | 3-4 | 5-6 | 7-8 |
| | 1 / 1 1/2 | 55 | 55 | 80 | 80 |
| | 2 / 2 1/2 | 55 | 55 | 80 | 80 |
| | 3 / 3 1/2 | 80 | 80 | 80 | 119 |
| | 4 / 4 1/2 | 80 | 80 | 119 | 119 |

(B) Add 50% of total household whirlpool bath water volume (gallons) to storage requirements.

(Example: 60 gallon whirlpool X .50 = 30 gallon addition to storage requirements).

* Two (2) concurrent showers (10 minute duration) at Design Heating Load conditions. Also one such shower concurrent with laundry.



JTG/Muir Manufacturer's Representative
4723 Tidewater Ave • Oakland, CA 94601 • (800) 493-8432 • (510) 434-3142 f • jtgmuir.com



Ultra High Efficiency Space Heating
and Water Heating at 97% efficiency
(Residential or Commercial)

Phoenix Combo System Sizing/Selection Estimator



COMBINED HYDRONIC SYSTEMS

SIZING ESTIMATOR

STEP 3 MODEL SELECTION USING BTU OUTPUT**

Select the Phoenix model that has the btu output that exceeds the minimum btu/hr required (Step 1) and has a storage capacity greater than Step 2 calculations.

| Model | Capacity (gal) | Max. Output (Btu/hr) |
|-------------------------|----------------|----------------------|
| PH 100-55 ¹ | 55 | 95,000 |
| PH 100-80 ¹ | 80 | 95,000 |
| PH 100-119 ¹ | 119 | 95,000 |
| PH 130-55 ¹ | 55 | 123,000 |
| PH 130-80 ¹ | 80 | 123,000 |
| PH 130-119 ¹ | 119 | 123,000 |
| PH 199-55 ² | 55 | 184,000 |
| PH 199-80 ² | 80 | 184,000 |
| PH 199-119 ² | 119 | 184,000 |

¹ Available July 2006 • ² Available Fall 2006



JTG/Muir Manufacturer's Representative
4723 Tidewater Ave • Oakland, CA 94601 • (800) 493-8432 • (510) 434-3142 f • jtgmuir.com



Ultra High Efficiency Space Heating and Water Heating at 97% efficiency (Residential or Commercial)

Benefits of using a Phoenix combo system:

- Heating components usually require only 120/60/1 “lighting circuits”. This results in reduced cost of electrical service and elimination of extra wiring and switch gear when using Phoenix Combo Systems over electric space heating and electric water heating.
- No special or two stage thermostats/controls are required except for dual fuel applications.
- No costly masonry chimney, or chimney liners or B-Vent or Stainless Steel pipe or flu chase construction required.
- One gas connection and one venting system requiring only one roof or wall penetration. No additional gas piping, or venting for single or multiple gas furnaces .
- Extremely flexible location in the structure requiring minimal space and no special combustion air ducting or lovers.
- No special high Amperage electrical service required.
- Simple multi-floor living space zoning using multiple air handlers operating independently at any desired temperature.
- Ducted air systems may be easily integrated with radiant floor systems in the same structure.
- Compatible with hi-velocity air handlers or conventional duct systems using fixed speed, or variable speed air handlers.
- Easily integrated into solar space heating and water heating systems.
- The ultimate in warmth and comfort for the living spaces.
- Copious amounts of hot water for almost any domestic water heating application all at 97% efficiency.
- Low energy consumption with maximum performance for the life of the system.



Ultra High Efficiency Space Heating and Water Heating at 97% efficiency (Residential or Commercial)

Phoenix Specifications

PHOENIX Recovery Capacities

| Model | Input BTU/hr | 40° rise | 50° rise | 60° rise | 70° rise | 80° rise | 90° rise | 100° rise | 110° rise | 120° rise | Gallon Capacity | First Hr Rating | Thermal % |
|-----------|--------------|----------|----------|----------|----------|----------|----------|-----------|-----------|-----------|-----------------|-----------------|-----------|
| PH199-119 | 199,000 | 575 | 460 | 383 | 329 | 287 | 256 | 230 | 209 | 192 | 119 | 335 Gallons | 96.3% |
| PH130-119 | 130,000 | 379 | 303 | 253 | 217 | 190 | 168 | 152 | 138 | 126 | 119 | 257 Gallons | 97.20% |
| PH100-119 | 100,000 | 293 | 235 | 196 | 168 | 147 | 130 | 117 | 107 | 98 | 119 | 214 Gallons | 97.8% |
| PH199-80 | 199,000 | 573 | 458 | 382 | 327 | 286 | 255 | 229 | 208 | 191 | 80 | 314 Gallons | 95.90% |
| PH130-80 | 130,000 | 376 | 301 | 251 | 215 | 188 | 167 | 150 | 137 | 125 | 80 | 227 Gallons | 96.40% |
| PH100-80 | 100,000 | 291 | 233 | 194 | 166 | 145 | 129 | 116 | 106 | 97 | 80 | 189 Gallons | 96.90% |
| PH199-55 | 199,000 | 573 | 458 | 382 | 327 | 286 | 254 | 229 | 208 | 191 | 55 | 295 Gallons | 95.90% |
| PH130-55 | 130,000 | 370 | 296 | 247 | 211 | 185 | 164 | 148 | 134 | 123 | 55 | 205 Gallons | 94.80% |
| PH100-55 | 100,000 | 288 | 230 | 192 | 165 | 144 | 128 | 115 | 105 | 96 | 55 | 169 Gallons | 95.90% |

PHOENIX Solar Recovery Capacities

| Model | Gallon Capacity | Input BTU/hr | Heated Water Volume of Gas Back-Up | Recovery Time | |
|------------|-----------------|--------------|------------------------------------|---------------|----------|
| | | | | 65° Rise | 90° Rise |
| PH199-119S | 119 | 199000 | 61 GAL | 7 MIN | 10 MIN |
| PH199-80S | 80 | 199000 | 41 GAL | 10 MIN | 14 MIN |
| PH130-119S | 119 | 130000 | 61 GAL | 11MIN | 15 MIN |
| PH130-80 | 80 | 130000 | 41 GAL | 15 MIN | 21 MIN |

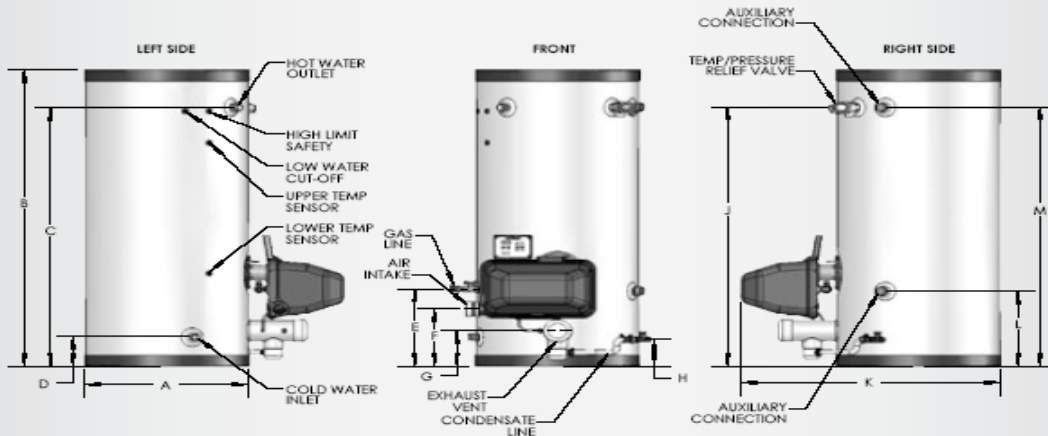

PHOENIX WATER HEATER DIMENSIONS

| MODEL # | GALLONS | A | B | C | D | E | F | G | H | J | K | L | M |
|---------|---------|-----|-----|---------|--------|---------|---------|---------|--------|---------|-----|---------|---------|
| PH-55 | 55 | 23" | 52" | 45" | 5" | 13-1/4" | 9-3/4" | 6" | 3-7/8" | 44-3/4" | 36" | 13" | 45" |
| PH-80 | 80 | 23" | 72" | 60" | 5-3/4" | 15-1/4" | 11-3/4" | 6" | 5-7/8" | 62-3/8" | 36" | 13" | 64-1/2" |
| PH-119 | 119 | 27" | 74" | 65-3/4" | 7-1/2" | 17" | 13-1/2" | 10-1/8" | 7-1/2" | 66-1/2" | 40" | 14-1/4" | 65-3/4" |

ALL DIMENSIONS ARE APPROXIMATE



Ultra High Efficiency Space Heating
and Water Heating at 97% efficiency
(Residential or Commercial)

Phoenix Specifications

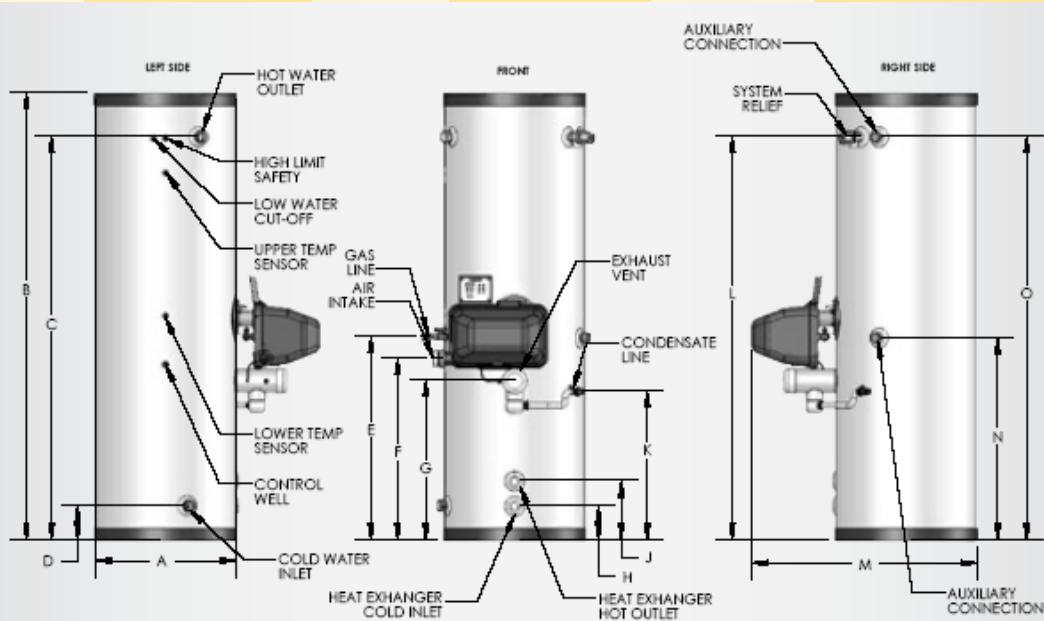

| PHOENIX SOLAR WATER HEATER DIMENSIONS | | | | | | | | | | | | | | | |
|---------------------------------------|---------|-----|-----|-----|--------|-----|-----|---------|--------|---------|---------|-----|-----|-----|-----|
| MODEL # | GALLONS | A | B | C | D | E | F | G | H | J | K | L | M | N | O |
| PH-80S | 80 | 23" | 72" | 64" | 5-1/4" | 32" | 29" | 25-1/2" | 5-3/4" | 9-3/4" | 27-3/4" | 64" | 36" | 32" | 64" |
| PH-119S | 119 | 27" | 74" | 66" | 7-1/4" | 34" | 31" | 27-1/2" | 7-1/2" | 11-1/2" | 25-3/4" | 66" | 40" | 34" | 66" |

ALL DIMENSIONS ARE APPROXIMATE

| PHOENIX WATER HEATER SPECIFICATIONS | | | | | | | | | |
|-------------------------------------|---------|-------------------|-------------------------------------|-----------------------------------|--------------------|----------------------|----------------------------------|--------------------|-----------------------------|
| MODEL # | GALLONS | BTU's | AIR INTAKE/ EXHAUST VENT SIZE | WATER INLET/ OUTLET SIZE | AUXILIARY CONN. | GAS LINE CONN. | SYSTEM RELIEF PIPE SIZE | SHIPPING WEIGHT | SOLAR SHIPPING WEIGHT |
| PH-55 | 55 | 100,000 & 130,000 | 2" | 1" NPT | 1" | 3/4" | 3/4" | 175 LBS. | N/A |
| | | 199,000 | 3" | | | | | | |
| PH-80 | 80 | 100,000 & 130,000 | 2" | 1-1/2" NPT | 1" | 3/4" | 3/4" | 235 LBS. | 245 lbs |
| | | 199,000 | 3" | | | | | | |
| PH-119 | 119 | 100,000 & 130,000 | 2" | 1-1/2" NPT | 1" | 3/4" | 3/4" | 405 LBS. | 415 lbs |
| | | 199,000 | 3" | | | | | | |

*For Solar Phoenix Only



**Your Best Value Choice In
Ultra High Efficiency Space
Heating and Water Heating
Today!**

Your investment in the only available 97% efficient, load matched, modulating combination space heating and water heating stainless steel tank system will reduce your fuel cost 35% to 60% (compared to conventional systems) for the life of the system!

Manufactured by:
Heat Transfer Products, Inc.
120 Braley Rd.
East Freetown, MA 02717
Visit us on the web at: www.htproducts.com